

SB.23FIXED HEIGHT RESTRICTION BARRIER

INSTALLATION INSTRUCTIONS

Read in full before starting

SAFETY

We recommend the following minimum precautions are taken:

- Wear appropriate clothing
- Eye protection and hand protection should be worn, including safety helmet
- Secure the site from pedestrians and vehicles, where applicable, by the use of high visibility tape, barriers, cones etc
- If you use a power supply, ensure that it is secure and in a safe dry location
- Ensure there are no underground services that may be affected

FEATURES

- To restrict the access of vehicles to controlled areas
- The gates can be unlocked and opened to allow access to controlled areas or closed and locked to prevent access
- The gate has a maximum swing of 180 degrees
- Latch back posts to lock on the open position are available at extra cost

MAINTENANCE

- Occasionally clean all surfaces with soap and water
- Check that the fixing bolts and other visible fixings are suitably tight and have not worked loose
- Check foundations remain firm
- Occasionally apply light oil (WD40 or similar) to the hinge if required

INSTALLATION INSTRUCTIONS

- Determine the correct position of Height Restriction Barrier
- Two rootings should be dug out 500mm square 800mm deep to accommodate hinge posts at the correct width
- The Height Restriction barrier should now be assembled to form a goal post type structure and can be lifted into position ensuring 760mm of each upright is below ground level.
- Before pouring concrete check that the correct clearance between road and crossbar is achieved and also ensure that barrier is square and level in the ground.
- The barrier can now be concreted in.
- If the gate is flanged for bolting down, ensure the surface is a suitable, flat, strong concrete
- Pre drill the four holes for the main flange bolts at 320mm center's
- Locate the main flange holes and bolt down

CONTINUED

Surface Mounted

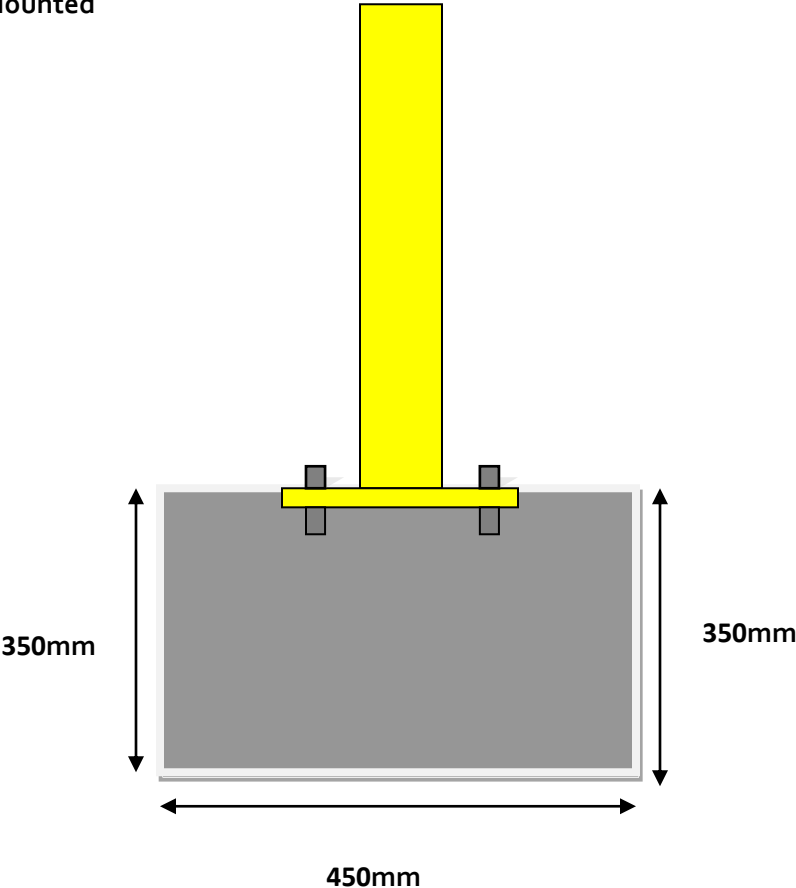

Sunken Permanent

